

Instructions for tempering the rough points/tips 240.000 for the BADECO mallets.

1. **Modify and/or sharpen** the rough point like your need. Do not forget to remove the point (mallet may be damaged)
2. **Hardening**. Hold point on thread part with tweezers (caution : do not damage the thread !). Heat up front part with blowlamp up to 820° (= light cherry-red). Cool down rapidly, putting tip head down into oil bath.
3. **To remove oil from point** use methylated spirits (or equivalent). Finish your modification with thin sand paper or a fine grinder. Important : do not touch point with your fingers !
4. **Tempering**. Finally, pass point from back to front over blowlamp up to 130° (straw-coloured) and cool immediately in oil bath. Should the temperature be too high (from dark orange to blue) point will lose its edge rapidly on first utilization. In that case start the whole process again beginning with 2.

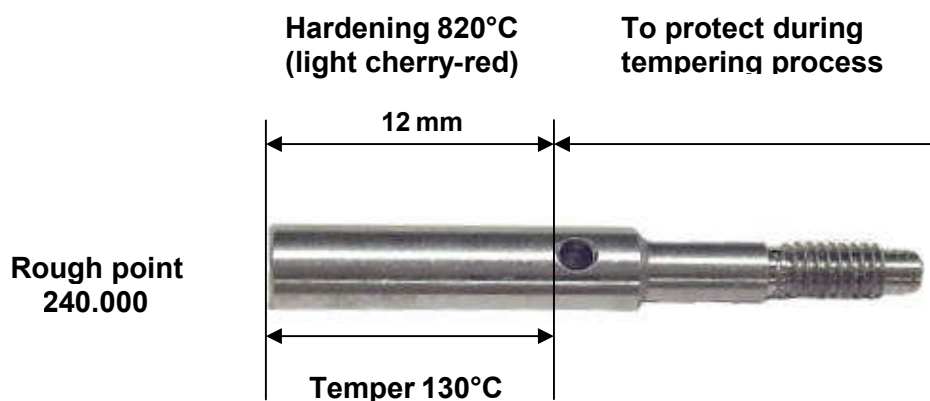

Variety of hardened points available in BADECO Geneva.

[Click here for more information.](#)

BADECO S.A.

Tel. 0041 22 329 01 91

Fax 0041 22 329 36 36

Email info@badeco-geneve.com

Internet www.badeco-geneve.com

POB 5621

1211 Geneva 11 / Switzerland